

2 Stage eXhaust 2SX HKS Exhaust Control System

SKYLINE GT-R (BNR34)

「Silence and High Power」

Valve switchable exhaust system "silence" and "high power" are implemented together.



CODE No. 31025-AN007

- A straight designed with $\phi 85$ pipe withstanding 650ps. Low exhaust pressure. (A special designed $\phi 85$ big valve is equipped.)
- The exhaust sound level at idle and street driving (low speed) is as low as the stock. No interference for communication with passengers.
- The valve is automatically controlled to maintain optimum timing.

【Exhaust Paths】

**@High Speed
Valve Opens**

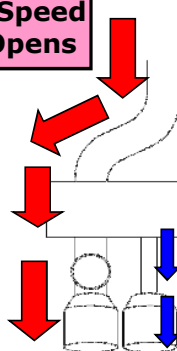

**@Low Speed
Valve Closes**

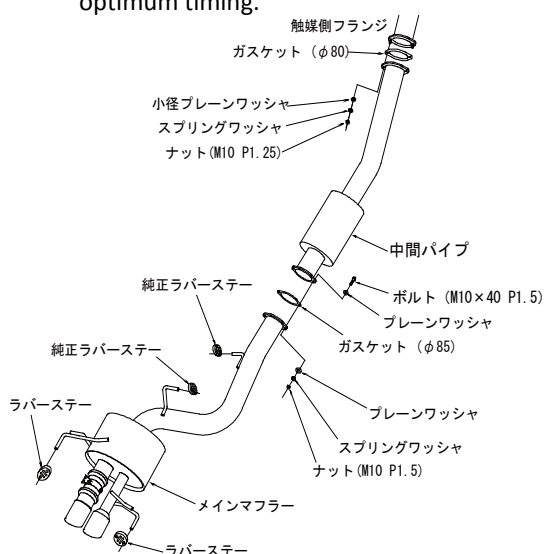
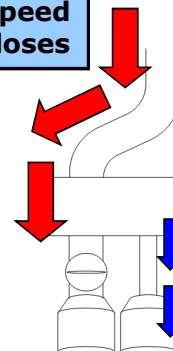

Model (Engine)	GF-BNR34 (RB26DETT)	
Model Year	1999/1~2002/8	
Main Material	SUS304	
Tip O.D.	$\phi 90 \times 2$	
Main Pipe Dia.	$\phi 85 \rightarrow \phi 85 \times 1, \phi 50 \times 1$	
Closed Noise	Stock	94dB (@Idling: 68dB)
	HKS	90dB (@Idling: 68dB)
(Noise Level @ Idling)	*Valve Fully Open	104dB (@Idling: 74dB)
Remarks	*Reference: Valve does not open when vehicle is stopped. Valve is fully open above 3300rpm and fully closed below 2800rpm	